

Amateur Radio Digital Modes

Jim Kajder, AF5FH
August 13, 2017

Introduction

- ▶ This presentation covers station and computer setup for the popular HF ham radio digital modes JT65, JT9, FT8, PSK31, and RTTY using a soundcard.

What is JT65?

- ▶ JT65A protocol was developed by Joe Taylor, K1JT in late 2003 for EME (earth-moon-earth) communications.
- ▶ JT65 uses 60 sec transmit/receive sequences and structured messages.
- ▶ Exchanges the minimum information needed for a QSO (Call Signs, Signal Reports, Grid Squares)
- ▶ Digital signal processing and redundancy allow up to 80% of the message to be lost and still be decoded correctly.

More about JT65

- ▶ During 126 intervals of 0.372 sec the waveform is one of 65 pre-defined tones.
- ▶ Bandwidth is 177.6 Hz.
- ▶ Accurate computer time (within 2 seconds) is required.
- ▶ Sound of JT65:



What is JT9?

- ▶ JT9 is similar to JT65 in that it uses 60 sec transmit/receive sequences and structured messages.
- ▶ The bandwidth of JT9 is 15.7 Hz, while the bandwidth of JT65 is 177.6 Hz.

What is FT8?

- ▶ Compared to the so called slow modes (JT9, JT65), FT8 is a few dB less sensitive but allows completion of QSOs four times faster. Bandwidth is greater than JT9, but about 1/4 of JT65A.
- ▶ Transmit/Receive sequence length: 15 seconds
- ▶ Bandwidth: 47 Hz
- ▶ FT8 stands for "Franke-Taylor design, 8-FSK modulation" and was created by Joe Taylor, K1JT and Steve Franke, K9AN.
- ▶ Recently I have heard more stations using FT8 than either JT65, JT9, or PSK31.

What is PSK31?

- ▶ PSK31 was developed by Peter Martinez, G3PLX in December 1998.
- ▶ Allows “real time” keyboard chat between two operators. Other stations see your typing immediately.
- ▶ “PSK” Phase Shift Keying modulates the phase of a carrier.

More about PSK31

- ▶ Typing speed is 50 wpm.
- ▶ Bandwidth is 62.5 Hz (about the same as 25 WPM CW).
- ▶ Uses varicode, frequently used characters are shorter than others.
- ▶ Sound of PSK31:



What is RTTY?

- ▶ After WW II, hams began using surplus radioteletype equipment.
- ▶ Allows “real time” keyboard chat between two operators. Other stations see your typing immediately.
- ▶ “RTTY uses a five-bit code (Baudot) to represent all the letters of the alphabet, the numbers, some punctuation and some control characters.
- ▶ At typical 45 baud each bit is $1/45.45$ seconds long, or 22 msec
- ▶ Typing speed is 60 WPM.

More about RTTY

- ▶ Bandwidth is 250 Hz.
- ▶ The standard mark and space tones are 2125 Hz and 2295 Hz.
- ▶ RTTY can be sent using either FSK (on/off keying, typically from COM port or LPT port) or AFSK (audio from a sound card).
- ▶ Sound of RTTY:



Why use Digital Modes?

- ▶ The equipment needed to connect your rig to a computer is very modest, and can be homemade or purchased at low cost.
- ▶ The software needed is free or low cost.
- ▶ PSK31 and JT65 modes work well with low power and simple antennas. RTTY is a popular mode for contests.
- ▶ Many hams use digital modes on HF, and contacts can be made anytime.

What Equipment is Needed?

- ▶ HF Transceiver capable of SSB and monitoring of ALC (can be an older rig, or beginner rig).
- ▶ Computer running Windows, Linux, or Mac OS.
- ▶ Soundcard Interface between the computer and the transceiver (can be homemade, and some rigs such as Icom 7200 have built-in USB interface). RTTY is generated using AFSK (audio frequency shift keying).
- ▶ HF antenna (simple wire antenna or vertical is fine).
- ▶ Software (free or low cost software is available).
- ▶ Optional hardware: CAT (computer aided transceiver control)

Homemade Interface

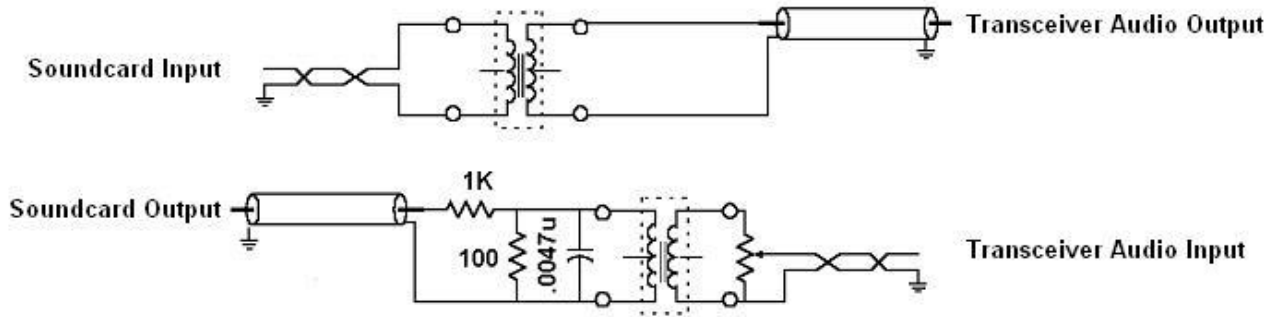

audio transformers: 1:1, 600 ohm (e.g. Radio Shack 273-1374)

KK7UQ

Commercial Interfaces

- ▶ Signalink USB
<http://www.tigertronics.com/slusbmain.htm>
- ▶ Rig Blaster
<http://www.westmountainradio.com/rigblaster.php>
- ▶ Unified Microsystems Sound Card Interface Kit
<http://www.unifiedmicro.com/sci6.htm>



The Computer

- ▶ For Windows a minimum 1.5 GHz dual core processor with 3 GB memory is recommended. Same for Linux.
- ▶ An external USB sound card or second internal sound card is recommended to avoid sending OS sounds over the air, and to allow ham software to use computer speakers.
- ▶ 16 bit (or higher) sampling rate recommended for sound card. WSJT-X recommends setting the sound card to 16 bit, 48000 Hz (DVD Quality).

Software

- ▶ Fldigi supports PSK31, RTTY, and many less used digital modes for Windows, Linux, and Mac OS-X.
<http://www.w1hkj.com/>
- ▶ WSJT-X implements JT65 and JT9 for Windows, Linux, and Mac OS.
<http://physics.princeton.edu/pulsar/K1JT/wsجتx.html>
- ▶ NetTime synchronizes the PC clock with Internet time, which is necessary for JT65 and JT9.
<http://timesynctool.com/>

Software (other choices)

- ▶ Ham Radio Deluxe is a popular software for PSK31 on Windows. It also supports RTTY and many less used digital modes. Version 5.24-38 is the last free version. The current version 6.4 sells for \$99.95.
<https://www.ham-radio-deluxe.com/>
- ▶ Tigertronics lists a variety of software that can be used with their Signalink
http://www.tigertronics.com/sl_soft.htm

Software (other choices)

- ▶ Several popular logging software packages support PSK31 and/or RTTY:
 - ▶ Logger32 <http://www.logger32.net/index.html>
 - ▶ N1MM Logger <http://n1mm.hamdocs.com>
 - ▶ Amateur Contact Log <http://www.n3fjp.com/index.html>

Hardware Installation

- ▶ Sound card interface manufacturers provide install instructions:
- ▶ Tigertronic Signalink
http://www.tigertronics.com/sl_suprt.htm
- ▶ West Mountain Radio
<http://www.westmountainradio.com/content.php?page=support>

Additional Software

- ▶ When operating JT65, the helper application JT-Alert <http://hamapps.com/> interfaces with either WSJT-X or JT-65HF and provides audio and visual alerts for:
 - ▶ Your Callsign decoded (someone calling you).
 - ▶ CQ & QRZ.
 - ▶ Wanted Callsign.
 - ▶ Wanted Grid (by Band).
 - ▶ Wanted US State (by Band).
 - ▶ Wanted DXCC (by Band).
 - ▶ Wanted CQ Zone (by Band).

Software Installation

- ▶ Installation instructions are available online:
- ▶ Fldigi <http://www.w1hkj.com/beginners.html>
- ▶ WSJT-X has a detailed User's Guide
<http://physics.princeton.edu/pulsar/K1JT/wsجتx.html>
- ▶ Meinberg NTP <http://wxtoimg.com/other/InstallNTP.pdf>

Additional Help

- ▶ Besides talking with folks at your local ham radio club, you can get help online. There are forums and groups for Fldigi, WSJT-X, JT-Alert, etc.
- ▶ <http://groups.yahoo.com/group/win-fldigi/>
- ▶ <https://groups.yahoo.com/neo/groups/wsjtgroup/info>
- ▶ <https://hamapps.groups.io/g/Support>

Fldigi

The screenshot displays the Fldigi software interface, titled "fldigi / Commander - AF5FH". The main window features a menu bar (File, Op Mode, Configure, View, Logbook, Help) and a toolbar with buttons for Spot, RxID, TxID, and TUNE. The central display area shows a frequency of 14070.000 kHz. Below this, there are fields for Frq (14070.455), On/Off (0225), In/Out, Call, Op, Az, Qth, St, Pr, and Loc. A list of received messages is visible on the left, including "14072.18 e", "14072.22 N7CGD N7CGD P", "14071.81 CQ de K6VN K6V", "14071.73 y? BTU Richar", and "14071.55 F de tna4rbn". The main text area contains a message in Morse code: "ež e Fetgeo kī me loia eage o ā onC e;ešh floi eO a,,ti eO ati eO at- er ati eO iaeeo niemel vti aeeSmet ofe iIBA Thanks for the reply. Name: Tom Tom QTH: Albuquerque, NM Albuquerque, NM LOC: DM65pe DM65pe BTU de K5TBA k Ke oRebtu T3aMtg e e a > eeot te ts s be". The bottom section includes a control panel with buttons for CQ, ANS, QSO, KN, SK, Report, Brag, T/R, Tx, Rx, and TX. A frequency scale from 500 to 3500 kHz is shown, along with a waterfall plot. The bottom status bar displays various settings: WF, -20, 70, x1, NORM, 455, QSY, Store, Lk, Rv, T/R, BPSK31, s/n 8 dB, imd -14 dB, -3.0, AFC, SQL, and KPSQL.

WSJT-X

The screenshot displays the WSJT-X software interface. At the top is a 'Wide Graph' window showing a frequency spectrum from 500 to 2500 kHz. Below it are control panels for 'Bins/Pixel 3', 'Start 0 Hz', 'Palette Adjust...', 'Flatten', 'Ref Spec', 'Spec 30%', 'JT65 2500 JT9', 'N Avg 5', 'Default', 'Cumulative', and 'Smooth 1'.

The main window is titled 'WSJT-X v1.8.0-rc1 by KI1JT' and contains a 'Band Activity' table and a 'Rx Frequency' table. The 'Band Activity' table has columns for UTC, dB, DT, Freq, and Message. The 'Rx Frequency' table has columns for UTC, dB, DT, Freq, and Message.

Below the tables are control buttons: Log QSO, Stop, Monitor, Erase, Decode, Enable Tx, Halt Tx, Tune, and Menu. A frequency display shows '14.074 000' and a signal strength indicator shows '47 dB'. There are also fields for 'DX Call', 'DX Grid', 'Lookup', and 'Add'. A 'Report -15' field shows '2017 Aug 13 03:05:57'. A 'Generate Std Msgs' section includes a list of messages and a 'Pwr' control.

At the bottom, there is a status bar showing 'Receiving', 'FT8', and '12/15 WD:6m'.

Band Activity					Rx Frequency				
UTC	dB	DT	Freq	Message	UTC	dB	DT	Freq	Message
030530	-15	-0.0	833	~ KG7GPM WC6YJ -03					
030530	-10	0.3	948	~ CQ ZL1MVL RF74					
030530	-14	0.0	2000	~ NORRO ZL3NB RRR					

Generate Std Msgs	Next	Now	Pwr
	<input type="radio"/>	Tx 1	
	<input type="radio"/>	Tx 2	
	<input type="radio"/>	Tx 3	
	<input type="radio"/>	Tx 4	
	<input type="radio"/>	Tx 5	
CQ AF5FH DM65	<input checked="" type="radio"/>	Tx 6	



Soundcard Level Set

- ▶ Right-click the white colored speaker icon located in the lower-right corner of your desktop and select "Recording Devices" from the pop-up menu.
- ▶ In the new window that opens, click one time on the "Microphone - USB Audio Codec" sound card to select it and then click the "Properties" button.
- ▶ In the Properties window that opens, click the "Levels" tab.
- ▶ Right-click the percentage display to the right of the Level slider and then select "decibels".
- ▶ Lower the Level slider to "0db" or as close as you can. This is "-0.4db" in Windows 7. It might be slightly different in Vista, Windows 8 and 10, but in any case, the closest value to 0db will work just fine. Note that you can use the left/right arrow keys to move the slider once you've clicked on it. This might be easier than using your mouse.
- ▶ Click OK, then click OK on the Recording Devices window.

Tuning Up

- ▶ Too much audio output from your soundcard will distort your signal. Typically, we set RF Power output from the transceiver to 100%, and adjust audio output from soundcard to achieve desired power output. ALC should be zero. Make sure that speech compression is off. Make sure microphone is turned off.
- ▶ With my vertical antenna, typical power output for JT65 is from 10 to 25 watts; PSK31 is from 20 to 40 watts; RTTY from 50 to 70 watts. Your power output will vary depending upon the efficiency of your antenna.

Receiver Settings

- ▶ For PSK31 and JT65, set your receiver AGC (automatic gain control) off if possible, otherwise set to slow.
- ▶ Turn the RF gain down to prevent overload of the sound card input and/or distortion.
- ▶ I have found that NB (noise blanker), NR (noise reduction) are best left turned off.
- ▶ Setting receiver filter to narrow, and using any notch filter capability is very helpful when working weak signals.

Suggested Operating Frequencies

FT8	JT65	PSK31	RTTY
3574 kHz	3576 kHz	3580 kHz	3580 to 3600 kHz
7074 kHz	7076 kHz	7035 kHz, 7070 kHz	7080 to 7100 kHz
14074 kHz	14076 kHz	14070 kHz	14080 to 14100 kHz
21074 kHz	21076 kHz	21070 kHz	21080 to 21100 kHz
28074 kHz	28076 kHz	28120 kHz	28080 to 28100 kHz

Hope to see you on the HF Digital Bands!